

WIRING RELAYS FOR KEY-SENSE WIRE ON COBALT, HHR, ION

- ▶ On 2006-Up Chevy Cobalt, HHR, and Saturn Ion vehicles, in addition to using a Passkey III bypass module, the WHITE/BLUE or WHITE wire needs to be interrupted using a relay. Wire as shown.

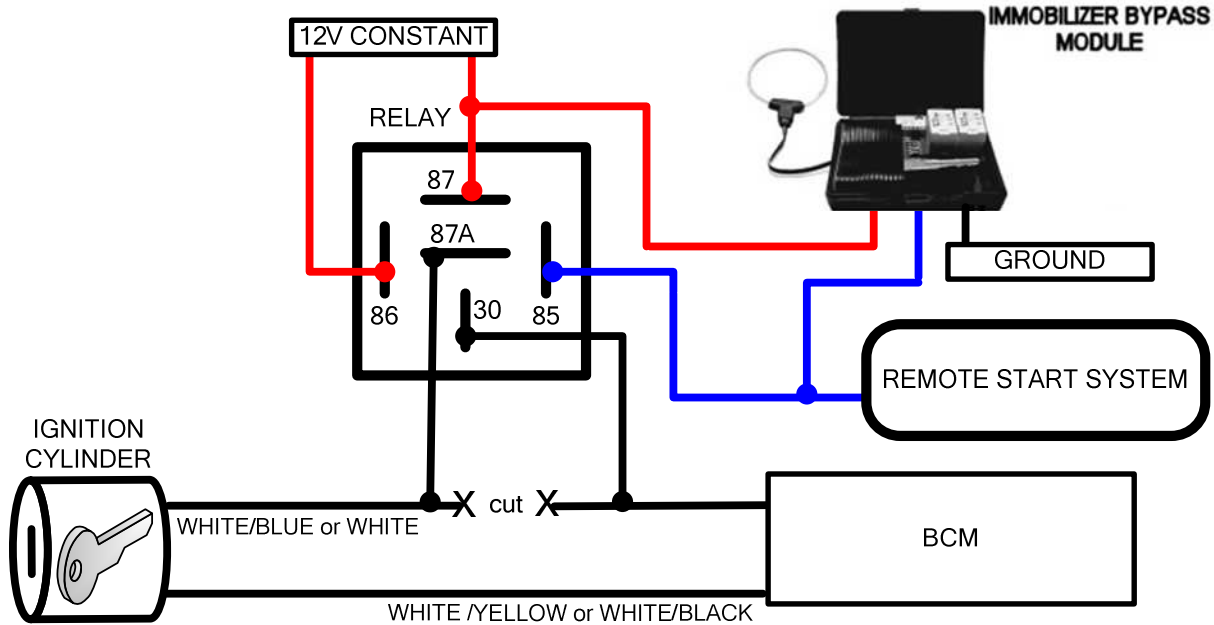

PIN	CONNECTION
85	TO (-) GROUND-WHEN-REMOTE-STARTED OUTPUT FROM REMOTE START
86	TO 12V CONSTANT
87	TO 12V CONSTANT
87A	TO WHITE/BLUE or WHITE WIRE (KEY CYLINDER SIDE)
30	TO WHITE/BLUE or WHITE WIRE (BCM SIDE)

Remote starter and security installations should be attempted by experienced security installers only. Information contained is accurate to the best of our knowledge and experience. Information contained is without any representation of warranty. It is the installer's responsibility to test and confirm all circuits with a digital multi-meter. Proper installation remains the responsibility of the installer. CarInstallExperts.com assumes no liability or responsibility resulting from an improper installation, even in reliance with the information contained in this guide.